

Underwater Wireless Sensor Node Design



Z. Jerry Shi
Department of Computer Science and Engineering
University of Connecticut

April 18, 2006

Building versatile yet efficient UWSN nodes

- Workload characterization
 - Many applications
 - New acoustic communication methods and networking protocols
- Efficient design
 - Hardware and software
- Resource management
 - Unique properties of acoustic channels
 - Dynamic network topology
 - Much more parameters to play with
 - Density, velocity, depth, water temperature, etc.

Layers in a sensor node

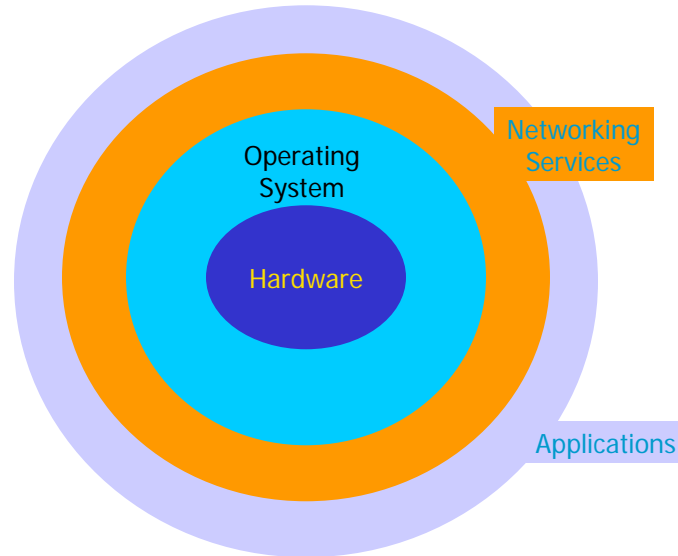

3

Typical structure of a sensor node

- Sensor probes
 - Interface circuitry
- Controller (processors)
- Trans-receiver
 - Acoustic modem
- Storage
- Battery
- Triggerable air-bladder

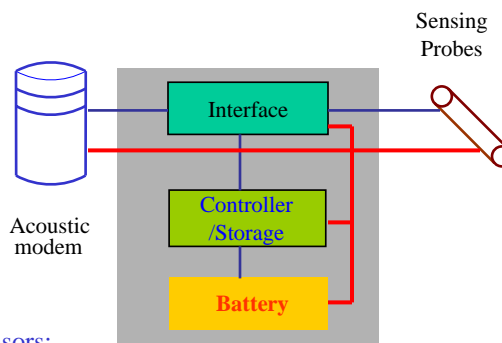

Different from land-based sensors:

- Larger and more expensive
- More power hungry
- Prone to failures

4

Underwater wireless sensor networks: application-driven

- Environmental monitoring and data collection
 - Temperature, salinity, ocean currents, etc.
 - Influences on climate and living conditions of plants and animals
 - Marine microorganism
 - Pollution
- Disaster early warning and prevention
 - Seismic monitoring
 - Tsunami
- Off-shore exploration and underwater construction
- Coastline protection and tactical surveillance
- Target detection
 - Mine
 - Shipwreck

5

Design goals of underwater sensor nodes

- **Versatile:**
 - Easy to customize for different applications
 - Satisfying performance
 - More computing capability than land-based sensor nodes
 - Storage
- **Resource efficient**
 - Low power
 - Low cost
 - Deployment of large amounts of nodes
 - Decomposable or retrievable
- **Reliable**

6

Diagram of sensor node board

ASIC, ASIP, FPGA, or off-the-shelf product ?

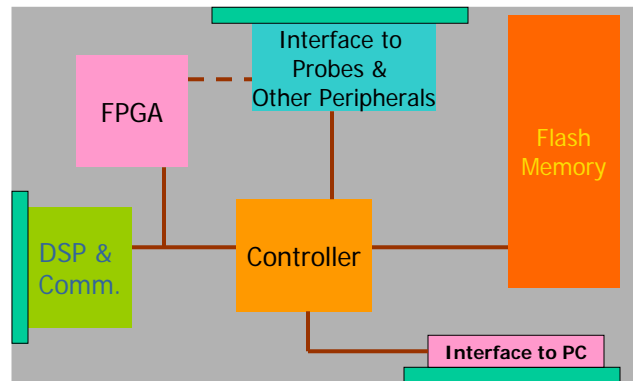

7

Implementation of OFDM-based acoustic modem

- We are optimizing the algorithm on TI DSP board (TMDSDSK6713)
 - TMS320C6713 at 225 MHZ
- Will explore other designs
 - FPGA and customized design

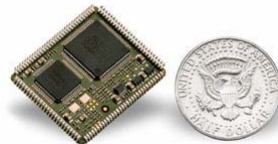

8

Prototype



9

Exploration of UWSN Operating System

- New workload requires more flexible OS
 - Small memory footprint
 - Low energy consumption
 - Responding to events promptly
 - Reprogrammable
 - Handling multiple events
 - Transparent management of large amount of memory
 - Easy to customize for different applications
- What kind of kernel structure?
 - Monolithic or microkernel
- What kind of execution model?
 - Event-driven or thread-based?

10

Comparison of existing OSES

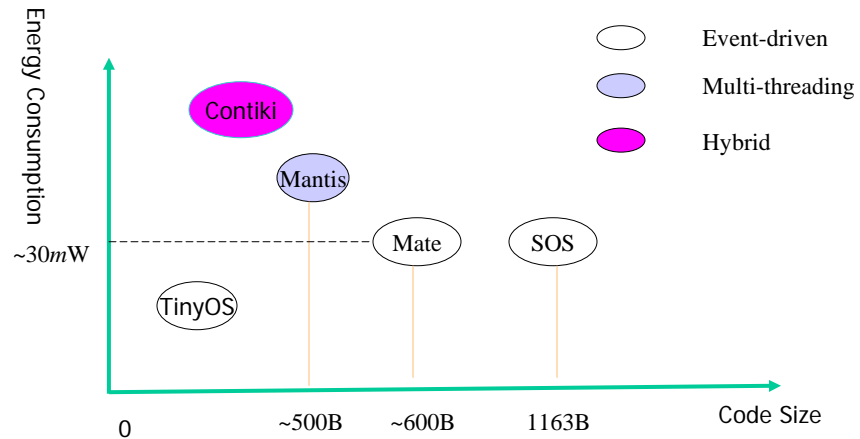

11

In the next year, ...

- Design the prototype node
 - Acoustic modem
 - Optimize the DSP implementation
 - Look into FPGA implementation
 - Sensor nodes
 - Design the sensor node board
 - OS
 - Start with embedded Linux
 - Explore customizable OS

12