

Architectural Challenges in Underwater Wireless Sensor Networks



UCONN

Z. Jerry Shi

Department of Computer Science and Engineering
University of Connecticut

UWSN Lab Kickoff Meeting, March 28, 2006

Building UWSN requires interdisciplinary collaborations

- Design challenges in UWSNs
 - Communications
 - Networking algorithms/protocols
- Architectural issues in UWSNs
 - Workload characterization
 - Energy-efficient design and resource management
 - Lifetime estimation

System design of UWSNs

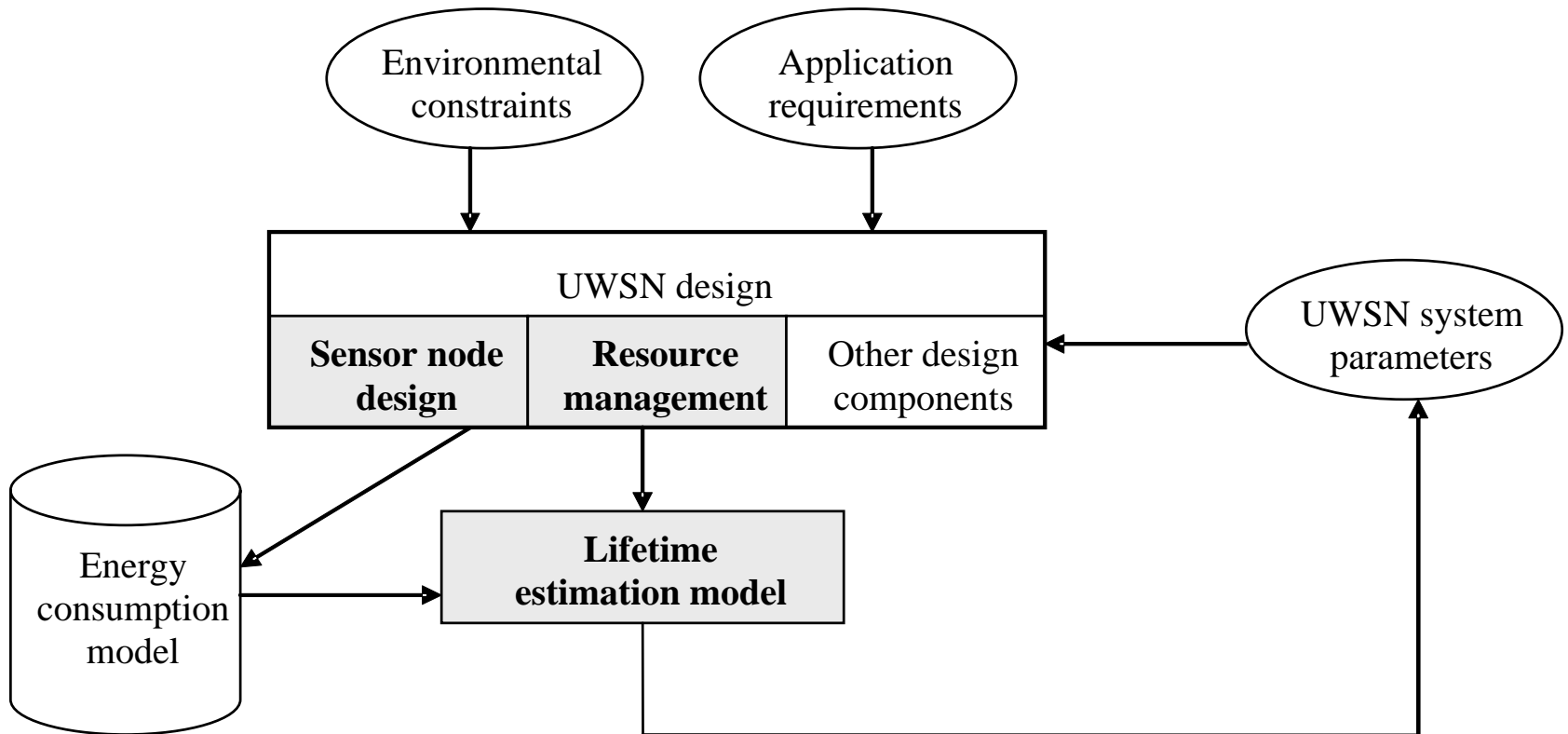

Typical structure of a sensor node

- Sensor probes
 - Interface circuitry
- Controller (processors)
- Trans-receiver
 - Acoustic modem
- Storage
- Battery
- Triggerable air-bladder

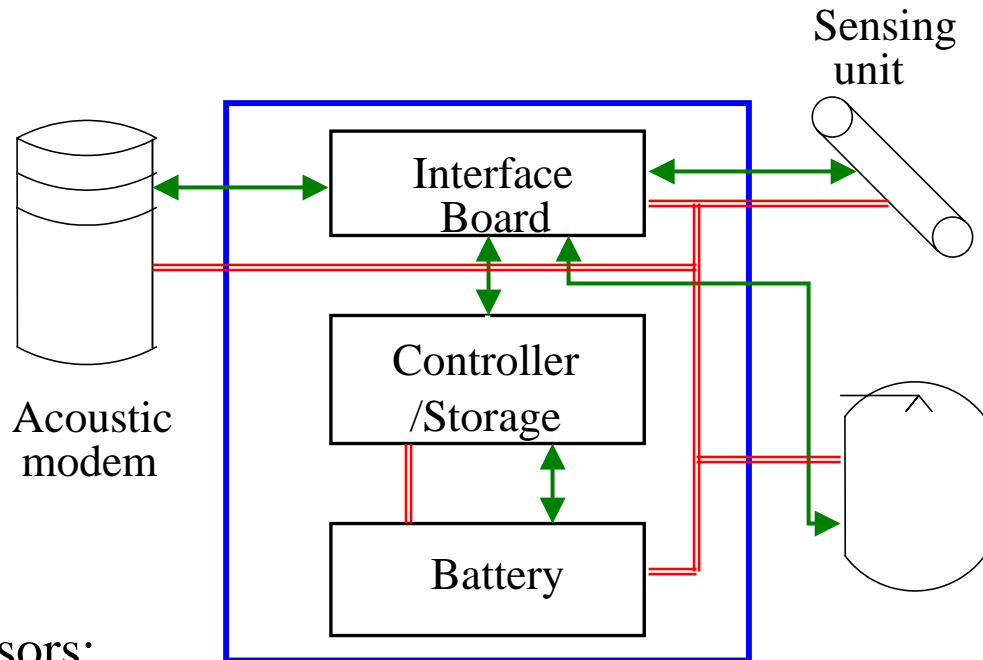

Different from land-based sensors:

- Larger and more expensive
- More power hungry
- Prone to failures

Triggerable air-bladder
for low-cost reusability purpose

Goals of underwater sensor nodes

- Easy to customize for different applications: workload characterization
 - Satisfying performance
 - Computing capacity
 - Storage
 - Bandwidth
- Long operation time: low power
 - Energy becomes more critical
 - Acoustic communications, memory, air-bladder, etc., more power-hungry
 - Energy harvesting difficult: solar and wind energy are not available
- Reliable operations
 - Fault tolerant
 - Secure
- Low cost: allows deployment of large amounts of nodes
 - Decomposable or retrievable

Energy-efficient design at the node level

- Design choices: ASIC, ASIP, FPGA, microcontroller
- Power-efficient design of individual components
 - Acoustic communication modules
 - Flexible packet relaying circuit
 - Only wake up the microcontroller when needed
- Proper task assignments and scheduling
 - Sampling, processing, storing, transmitting, receiving, and forwarding
- Exploiting opportunities in the underwater environment
 - Long and frequent sleep mode due to the long delay of acoustic channels

In the near future, ...

- Prototype node built with off-the-shelf parts
 - PDA
 - Acoustic modem
 - Sensor
 - Interface board
- Investigating simulators for workload characterization
 - Data types and traffic patterns of specific applications
 - Routing and localization algorithms
 - Processors
 - Performance, power, etc.